

**TV Video Modulator**

The MC1373 is an RF oscillator and dual-input modulator to generate a TV signal from baseband video inputs.

Applications include video games, home computer display, video tape recorders, and test equipment.

The very low level of intermodulation products, compact package and small external component count make this device superior to simple discrete circuits.

- Single 5.0 Vdc Supply
- Channel 3 or 4 Operation
- Excellent Oscillator Stability to 100 MHz
- Color and Sound Compatibility
- Dual Input Modulator for Ease of Signal Handling
- Low Intermodulation (-50 dB, 920 kHz Beat)
- Overmodulation Protection

**MAXIMUM RATINGS** ( $T_A = 25^\circ\text{C}$ , unless otherwise noted.)

Rating	Value	Unit
Supply Voltage	8.0	Vdc
Operating Ambient Temperature Range	0 to +70	$^\circ\text{C}$
Storage Temperature Range	-65 to +150	$^\circ\text{C}$
Junction Temperature	150	$^\circ\text{C}$
Power Dissipation Package	1.25	W
Derate above 25 $^\circ\text{C}$	10	mW/ $^\circ\text{C}$

**TV VIDEO  
MODULATOR CIRCUIT**

**SILICON MONOLITHIC  
INTEGRATED CIRCUIT**



**P SUFFIX**  
**PLASTIC PACKAGE**  
**CASE 626**

**PIN CONNECTIONS**

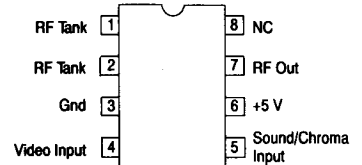

9

**Figure 1. Block Diagram and Application Circuit**

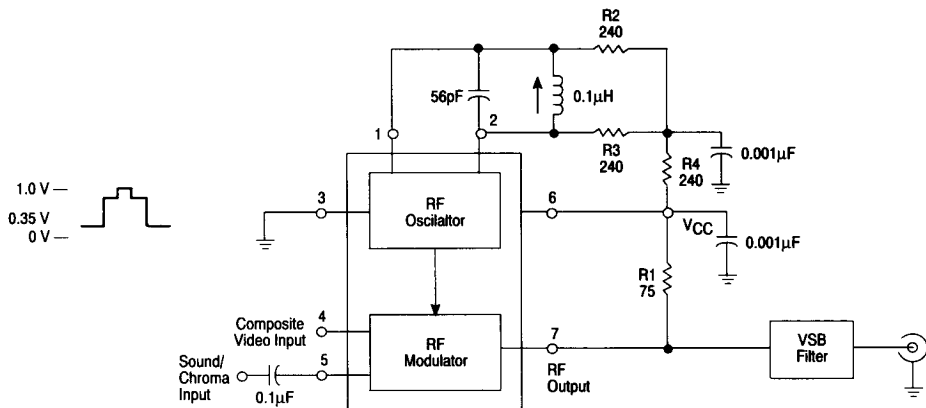



# MC1373

Figure 4. Schematic Diagram

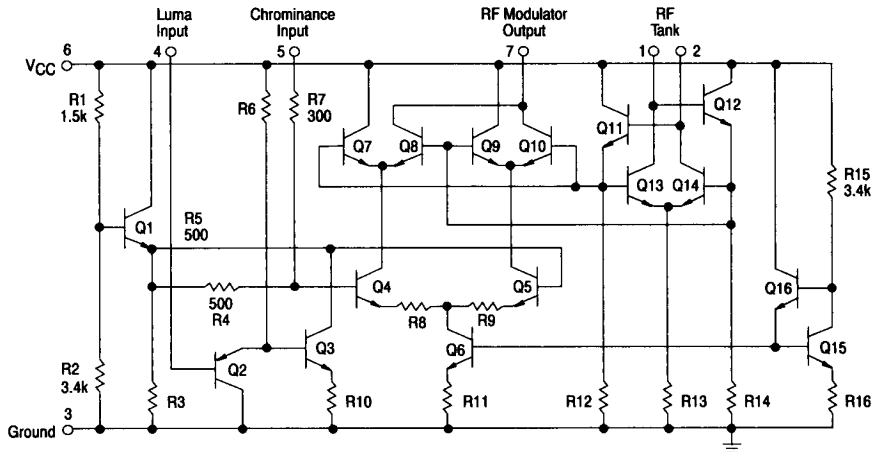

## SCHEMATIC DESCRIPTION

The RF oscillator consists of differential amplifier Q13 and Q14 cross-coupled through emitter followers Q11 and Q12. The oscillator will operate at the parallel resonant frequency of the network connected between Pins 1 and 2. The oscillator output is used to switch the doubly balanced RF modulator, Q4 through Q10. Transistors Q2 and Q3 provide level shifting and a high input impedance to the luminance input Pin 4. The bases of transistors Q4 and Q5 are both biased through resistors R4 and R5, respectively, to the same DC reference voltage at Q1 emitter. The base voltage at Q5 may only be offset in a negative direction by luminance signal current source Q3. This design insures that overmodulation due to the luminance signal will never occur. The chrominance signal is externally AC coupled to Pin 5 where it is reduced by resistor dividers R7 and R4, and added to the luminance signal in Q4. The resultant differential composite video currents are switched at the appropriate RF frequency in Q7 through Q10. The output signal current is presented at Pin 7.

Transistors Q15, Q16 and resistors R15, R16 provide a highly stable voltage reference for biasing the current source Q6.

## OPERATIONAL DESCRIPTION

**Pins 1 and 2 — RF Tank.** A tuned circuit connected between these pins determines the RF oscillator frequency. The tuned circuit must provide a low DC resistance shunt. Applying a DC offset voltage between these pins results in baseband composite video at the RF Modulator Output.

**Pin 3 — Ground.**

**Pin 4 — Luminance Input.** Input to RF modulator. This pin accepts a DC coupled luminance and sync signal. The amplitude of the RF signal output increases with positive voltage applied to the pin, and ground potential results in zero output (i.e., 100% modulation). A signal with positive-going sync should be used.

**Pin 5 — Chrominance/Sound Input.** Input to the RF modulator. This pin accepts an AC coupled chrominance

signal. The signal is reduced by an internal resistor divider before being applied to the RF modulator. The resistor divider consists of a 300  $\Omega$  series resistor and a 500  $\Omega$  shunt resistor. A 4.5 MHz FM audio signal may be added to the input by selecting an appropriate series input resistor to provide the correct Luminance:Sound ratio.

**Pin 6 — VCC.** Positive supply voltage.

**Pin 7 — RF Modulator Output.** Common collector of output modulator stage. Output impedance and stage gain may be selected by choice of resistor connected between this pin and DC supply.

**Pin 8 — No Connection.**

## APPLICATIONS INFORMATION

### RF Modulator and Oscillator

The coil and capacitor connected between Pins 1 and 2 should be selected to have a parallel resonance at the carrier frequency of the desired TV channel. The values of 56 pF and 0.1  $\mu$ H shown in Figure 1 were chosen for a Channel 4 carrier frequency of 67.25 MHz. For Channel 3 operation, the resonant frequency should be 61.25 MHz ( $C = 75$  pF,  $L = 0.1$   $\mu$ H). Resistors R2 and R3 are chosen to provide an adequate amplitude of switching voltage, whereas R4 is used to lower the maximum DC level of switching voltage below VCC, thus preventing saturation within the IC.

Composite Luminance and Sync should be DC coupled to Luminance Input, Pin 4. This signal must be within the Luma Input Dynamic Range to insure linearity. Since an increase in DC voltage applied to Pin 4 results in an increase in RF output, the input signal should have positive-going sync to generate an NTSC compatible signal. As long as the input signal is positive, overmodulation is prevented by the integrated circuit.

Chrominance information should be AC coupled to Chrominance Input, Pin 5. This pin is internally connected to a resistor divider consisting of a series 300  $\Omega$  and a shunt 500  $\Omega$  resistor. The input impedance is thus 800  $\Omega$ , and a coupling capacitor should be appropriately chosen.